



## ***INSTRUCTION MANUAL***

***OMNI Lower***

***OMNI .22***

***OMNI 5.56***

***OMNI .410***

**ATTENTION: BEFORE REMOVING THE  
FIREARM FROM ITS PACKAGE READ &  
UNDERSTAND WARNINGS AND FULL  
INSTRUCTIONS AND PRECAUTIONS IN THIS  
OWNER'S MANUAL**

**INDEX**

<i>Warnings</i>	<b>3</b>
<i>Safety rules</i>	<b>4</b>
<i>Instructions for use</i>	<b>6</b>
<i>Ammunition</i>	<b>6</b>
<i>Assembly</i>	<b>8</b>
<i>Loading</i>	<b>9</b>
<i>Firing</i>	<b>11</b>
<i>Unloading</i>	<b>11</b>
<i>Clearing misfires</i>	<b>12</b>
<i>Diassembly</i>	<b>12</b>
<i>Cleaning</i>	<b>12</b>
<i>Ordinary and extraordinary maintenance</i>	<b>13</b>
<i>Troubleshooting tips</i>	<b>14</b>
<i>Warranty</i>	<b>16</b>
<i>Notes</i>	<b>20</b>



## WARNINGS

**PLEASE BE AWARE THAT A CONVERSION KIT IS NOT A WEAPON WHEN NOT ATTACHED TO AN UPPER. HOWEVER, WE WISH TO POINT OUT ALL THE SAFETY RULES THAT APPLY FOR THE USE OF ALL WEAPONS IN GENERAL.**

American Tactical is not responsible for damage to objects caused by misuse of the gun or for injuries to persons or animals, or in case of death, caused voluntarily or involuntarily by the gun user.

American Tactical is not responsible for injuries caused by poor maintenance, misuse of the gun, unauthorized or improper modifications.

American Tactical declines responsibility for the indirect consequences of any injuries and / or death of persons or animals, damage to objects caused by use of the gun or by primer explosion, by bullet's ricochet, or unsafe loading practices and / or procedure.

The complete and full knowledge of your firearm may help you to avoid serious injuries due to lack of safety devices.

Read the entire manual and learn the proper use of the gun without live ammunition. It is important that you understand the proper use of this product. The life of the people close to you may depend on your safety.

If the manual is not clear, please contact the dealer where you bought the gun or call the distributor or the manufacturer by using the contact information provided within this manual.

**THIS UPPER IS NOT DESIGNED TO BE USED WITH 50 BMG. DO NOT attempt use this caliber. This will void any and all warranties and we specifically disclaim for any damage or injury whatsoever occurring in connection with the fore mentioned.**



## SAFETY RULES

1. Read the instructions carefully before use. Reading the manual and a careful examination of the gun are fundamental to avoid any kind of problem.
2. Be aware that you are handling a firearm; therefore your knowledge and behaviour may affect your life and those of the people close to you.
3. Guns and ammunitions must be kept in different places
4. **ALWAYS** keep guns and ammunitions out of reach of children.
5. Store the gun in a clean dry and airy place after use to avoid rust in mechanical parts that may cause serious problems in functioning after a period of inactivity.
6. The gun must **ALWAYS** be stored unloaded, **ALWAYS** check that the chamber is empty.
7. Keep away from open flame or heating sources.
8. Never leave a loaded gun unattended.
9. Never leave the weapon loaded and with a closed breech block.  
Always point the gun in a safe direction, and handle it as though it were loaded. This is especially important when loading and unloading the gun, and when handing it to someone else. Never take someone's word that it is unloaded. Always make sure the gun is unloaded before laying it down or handing it to someone else.
10. After use, clean and lubricate the inside of the barrel with appropriate oil. Avoid grease or oil build up that can cause excessive pressure and result in serious personal injuries. Before using the gun again, inspect the barrel and chamber to make certain that there are no obstructions in the bore. Remove any oil residue with rod and dry patch before shooting.
11. Accumulation of rust in the barrel can cause excessive pressures resulting in serious injury and may cause the explosion of the barrel. A rusted, pitted or eroded barrel should be replaced.
12. Wash hands thoroughly after shooting and handling firearms to remove any unwanted residues.
13. Developing intelligent, good safety habits is the best way to prevent accidents.
15. **ALWAYS** keep the gun unloaded when transporting it from home to the shooting areas. Carefully check that cartridge chamber is empty.
16. When you walk around with the gun in a shooting area, **ALWAYS** keep the muzzle pointed in a safe direction.



17. NEVER run with a loaded gun, don't cross any obstacle (fences or water courses, etc.) or walk where there is any possibility of slipping or falling without having your firearm unloaded and in safety position.
18. Do not smoke while handling, loading or shooting any ammunition, especially black powder. Keep black powder in a closed container at all times, reclosing the container after each and every use.
19. Never drink alcoholic beverages or take any drugs before or during shooting, as this not only constitutes criminal disregard for your safety and that of others, but will seriously impair your judgment and vision. Never use a gun while you are taking medication unless you have checked with your doctor to ensure your fitness to handle the gun safely.
20. Never rest your finger on the trigger until the very moment you wish to shoot. Always keep the safety on until you are ready to safely shoot at an intended target (see safety features).  
Note: Safety devices on guns are extras and are not a substitute for your proper and safe handling practices.
21. Always wear and encourage others near you to wear proper ear protection when shooting, especially on a range since the noise from your gun, and other guns close to you, could result in permanent hearing loss.
22. Always wear protective shooting glasses to protect your eyes from injury by gun powder, gas, lubricant, dirt or metallic particles, carbon residue, sparks or other debris.
23. Use exclusively factory loaded ammunition of the caliber specified on the firearm barrel. Use of different calibers may cause serious personal injuries to you and to people close to you.
24. Before shooting ALWAYS check to ensure that the barrel is free of obstructions.
25. When selecting a place to shoot, always be absolutely sure of your target and the area behind it before you touch the trigger, making sure there is an adequate backstop which will stop and contain bullets. A bullet can travel through or past your target up to 1 1/2 miles. If you have any doubt, do not shoot.
26. Keep all bystanders behind you, standing beside a shooter is not a safe position. Make sure all other shooters and bystanders are well away from the ejection port.
27. Never shoot against a solid surface or in a pool of water, the projectiles could ricochet and shoot toward any direction. Don't shoot up into the sky.
28. Never force a jammed action. It could cause an explosion of the round and consequent injury.
29. In case of misfire, manually extract the cartridge from the chamber. If firearm fails to fire when trigger is pulled, as a result of slow primer ignition (hangfire), keep muzzle pointed downrange for a minimum of 30 seconds. If the round does not fire, remove the magazine, clear the weapon and examine the ejected, unfired cartridge. If the indent from the firing pin is off center, light or absent,



take the gun to a competent gunsmith. If the indent appears normal compared to other rounds, assume a faulty round, separate from other cartridges, reload and continue shooting.

30. Do not attempt to re-use unexploded ammunitions.

31. NEVER modify any parts of your gun. Any alteration may cause serious personal injury and voids the warranty.

32. Only a qualified gunsmith may service the gun for repair or serious maintenance.

American Tactical declines any responsibility for misuse of the firearm.

In case of alteration of the firearm, American Tactical declines any civil and penal responsibility and will not refund any damage.

**The user is responsible for injuries or damages caused to him or to other persons.**

COMPLETE KNOWLEDGE OF YOUR FIREARM CAN MAKE THE DIFFERENCE.

**QUALITY INSPECTION: Every firearm is thoroughly inspected for function and cosmetic blemish prior to shipment**

## **INSTRUCTIONS FOR USE**

### **Ammunition**

**ATTENTION: For best performance of the OMNI we recommend the use of quality ammunition high velocity and no reloads**

**Please allow 100-150 rounds for initial "Break-In" period**

#### **NOTICE**

WE SPECIFICALLY DISCLAIM RESPONSIBILITY FOR ANY DAMAGE OR INJURY WHATSOEVER OCCURRING IN CONNECTION WITH, OR AS THE RESULT OF, THE USE OF FAULTY, OR NONSTANDARD, OR "REMANUFACTURED" OR HANDLOADED (RELOADED) AMMUNITION, OR OF CARTRIDGES OTHER THAN THOSE FOR WHICH THE FIREARM WAS ORIGINALLY CHAMBERED.

- ∞ Death, serious injury, and damage can result from the use of wrong ammunition; bore obstructions, powder overloads, or incorrect cartridge components.
- ∞ Use only ammunition specifically recommended for your firearm (Proper Ammunition specified on barrel and cylinder).
- ∞ Always use cartridges whole length is equal or inferior to that indicated on the barrel.



- ∞ Use only high quality, original factory manufactured ammunition whose pressure cannot be higher than the one rated by S.A.A.M.I. or C.I.P.
- ∞ For best results, we recommend the use of jacketed round nose ammunition
- ∞ Your gun has been designed for ammunition of a specific caliber – do not alter the barrel, chamber, caliber for which your gun was designed.
- ∞ Be sure you never mix ammunition.
- ∞ Firearms may be severely damaged, and serious injury to the shooter or others may result from any condition causing excessive pressure inside the chamber or barrel during firing. Excessive pressure can be caused by obstruction in the barrel, propellant powder overloads, or by the use of incorrect or defectively assembled cartridges. In addition, the use of a dirty, corroded or damaged cartridge can lead to a burst cartridge case and consequent damage to the firearm and personal injury from the sudden escape of high-pressure propellant gas within the firearm's mechanism.
- ∞ Immediately stop shooting and check the barrel for a possible obstruction whenever:
  - You have difficulty in, or feel unusual resistance in chambering a cartridge
  - A cartridge misfires (does not go off)
  - The mechanism fails to extract a fired cartridge case
  - Unburned grains of propellant powder are discovered spilled in the mechanism
  - A shot sounds weak or abnormal
  - In such cases it is possible that a bullet is lodged part way down the barrel. Firing a subsequent bullet into the obstructed barrel can damage the firearm and cause serious injury to the shooter or bystanders.
- ∞ Bullets can become lodged in the barrel:
  - If the cartridge has been improperly loaded without propellant powder, or if the powder fails to ignite. (Ignition of the cartridge primer alone will push the bullet out of the cartridge case, but usually does not generate sufficient energy to expel the bullet completely from the barrel)
  - If the bullet is not properly seated tightly in the cartridge case. When such a cartridge is extracted from the chamber without being fired, the bullet may be left behind in the bore at the point where the rifling begins. Subsequent chambering of another cartridge may push the first bullet further into the bore.
- ∞ If there is any reason to suspect that a bullet is obstructing the barrel, immediately unload the firearm and look through the bore. It is not sufficient to merely look in the chamber. A bullet may be lodged some distance down the barrel where it cannot easily be seen. If a bullet is in the bore, do not attempt to shoot it out by using another cartridge, or by blowing it out with a blank or one from which the bullet has been removed. Such techniques can generate excessive pressure, damage the firearm and cause serious personal injury. If the bullet can be easily removed with a wood or brass dowel, (using hand pressure only, never "hammer" a bullet lodged in the bore) clean any unburned powder grains from the bore, chamber and mechanism before resuming shooting. If the bullet cannot be dislodged by tapping it with a cleaning rod, take the firearm to a gunsmith.
- ∞ Dirt, corrosion, or other foreign matter on a cartridge can impede complete chambering and may cause the cartridge case to burst upon firing. The same is true of cartridges which are damaged or deformed.
- ∞ Don't oil cartridges, and be sure to wipe the chamber clean of any oil preservative before commencing to shoot. Oil interferes with the friction between cartridge case and



chamber wall that is necessary for safe functioning, and subjects the firearm to stress similar to that imposed by excessive pressure.

- Use lubricants liberally on the moving parts of your firearm. Avoid excessive spraying of any aerosol gun care product, especially where it may get on ammunition. All lubricants, and aerosol spray lubricants in particular, can penetrate cartridge primers and cause misfires. Some highly penetrative lubricants can also migrate inside cartridge cases and cause deterioration of the propellant powder; on firing, the powder may not ignite. If only the primer ignites, there is a danger that the bullet may become lodged in the barrel.

**The use of reloaded or improper ammunition voids the warranty.**

## **Assembly**

Disassemble the upper part of your weapon pushing the two pins (manually or with the special key) as indicated in picture no. 1. Remove the original charger.

Mount the upper of choice leaning it on the front thrust bridge first, fix the front blocking pin, then lean the upper onto the lower part. Please make sure the hammer is cocked, or the upper cannot be pushed down onto the lower part. Insert the back locking pin.

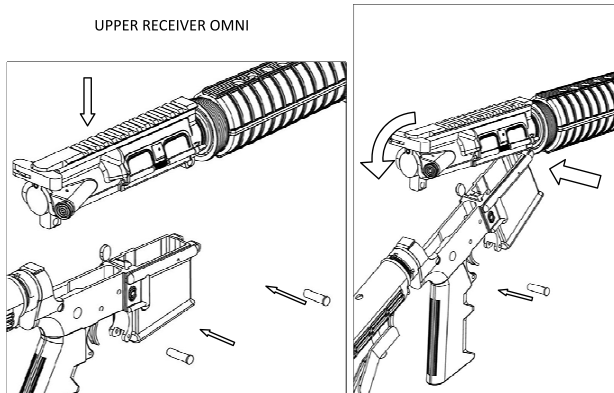



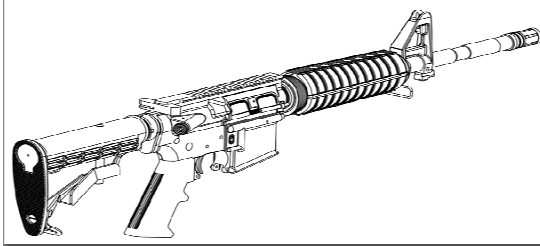

NOTE : there are several "M16" models on sale, which have a different front and rear pin. You can use the special adaptors supplied by all major parts suppliers.

Make sure that the breech bolt is completely inside its housing and does not protrude. The bolt must also be pushed down completely, with the openings into the corresponding notches.

DO NOT BLANK SHOOT

## **Loading**

**Warning:** Make sure that the firearm is unloaded (chamber cleared, barrel clear of any obstructions, magazine empty) for inspection and that the safety is in the safe position. Keep muzzle pointed in safe direction and follow all safety procedures at all times. Practice these steps with an unloaded gun or dummy ammo until you are completely familiar and comfortable with the procedures. Use live ammo only when you are prepared to shoot. Always use clean, dry, high quality ammunition (of the proper caliber) that meets industry performance standards.

1. Press magazine release and remove empty magazine (fig. 5).



2. Insert the loaded magazine until the magazine catch locks it in position (fig. 7).

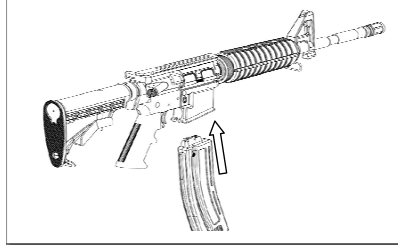

3. To load the chamber with the first cartridge, pick up the firearm with your shooting hand and point the muzzle in a safe direction.
4. Use your other hand to retract and release the bolt with the help of the charging handle. As the bolt travels forward it inserts the first round into the chamber. The hammer is now cocked. Leave the safety in the safe position until you are ready to fire.

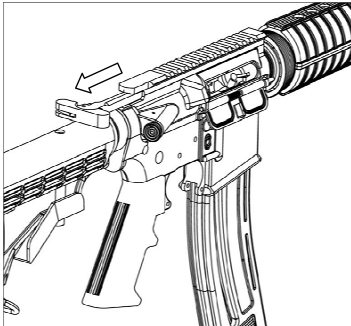
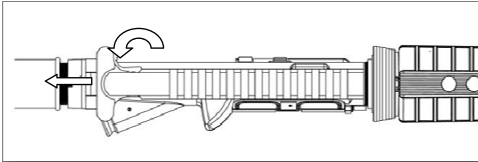

**WARNING: Never put your hand in front of the muzzle.**  
Always load a round into the chamber by feeding it from the magazine.



**COLT M4/M16 are designed so that they are able to fire when the magazine is removed. therefore, if the magazine is removed from the firearm and there is a loaded round in the chamber, it will fire if the trigger is pulled. After inserting a magazine, always test to make sure it is locked in place by applying some removal pressure to the magazine.**

Your firearm is now ready to fire. Keep your finger off the trigger and **out of the trigger guard until you are ready to fire.**

## **Firing**

Grasp firearm with one hand on forearm and other hand on grip with index finger resting along outside of trigger guard. Raise firearm and pull buttstock firmly into shoulder.

Aim at a safe target. Push the manual safety to the fire position. Squeeze the trigger slowly and maintain the pressure until the round is fired.

Your firearm loads immediately after firing.

- You may continue to fire by pulling and fully releasing the trigger until the magazine is empty  
- If you wish to stop, release trigger, remove finger from triggerguard, and set safety selector to "SAFE"

position. Remove cartridges as explained under section "Unloading"

- If you decide not to fire after the hammer has been cocked or if you decide to suspend firing, keep the firearm pointed in a safe direction.

- Remove your finger from within the trigger guard.

- Place the manual safety in the "SAFE" position and remove the magazine.

- Pull charging handle rearward to eject any remaining cartridge(s).

Make sure that the firearm is unloaded (magazine removed, chamber and barrel cleared)

- You must be certain there is no cartridge in the chamber or obstructions in the barrel.

Remember that any time you release the bolt while a magazine containing cartridges is in the firearm, you will have reloaded the firearm and it will be capable of firing.

Release the upper from the back removing the back locking pin, then pull the trigger while gently accompanying the hammer (in order not to blank fire)

**Keep the firearm pointed in a safe direction when decocking. Failure to do this can result in serious injury or death.**

## **Unloading:**

1. Point the muzzle in a safe direction.
2. Remove the magazine.
3. Ensure that the chamber is empty by pulling back the charging handle to visually inspect the chamber. Keep firearm pointed in a safe direction.
4. Retract the charging handle so that the bolt moves into battery.
5. Push the manual safety to the "fire" position.
6. Squeeze trigger to decock the firearm. The firearm may now be carried safely.

**Keep the firearm pointed in a safe direction when unloading. failure to do this can result in serious injury or death.**



## **Clearing misfires**

**Warning: If your firearm gives any indication that it is not performing properly or the operation of your firearm has changed “the way it feels or sounds”, stop firing. Make sure the firearm is pointed in a safe direction, unload the firearm and have it inspected and test fired by a qualified gunsmith.**

1. If a cartridge fails to fire, wait 30 seconds while keeping the muzzle pointed in a safe direction. Keep your finger off the trigger and out of the trigger guard.
2. Place the manual safety in the “SAFE” position
3. Remove the magazine.
4. Grasp the bolt with the charging handle and briskly pull it fully rearward to eject the misfired round.
5. Check the barrel chamber and bore visually for any obstructions. Never look down the barrel from the muzzle end. You must be certain there are no cartridges in the chamber or obstructions in the barrel.

**Remember that any time you release the bolt while a magazine containing cartridges is in the firearm, you will have reloaded the firearm and it will be capable of firing.**

**Note: the forward assist plunger is not in function. In case of feeding failures, retract the charging handle to extract the damaged round.**

**Warning: Never try to use a misfired cartridge again.**

## **Disassembly (field stripping)**

**Always follow the disassembly instructions exactly. Never do anything beyond what you are specifically instructed to do in this manual. Never alter or modify the parts in your firearm.**

Prior to disassembly, place the manual safety in the safe position, take **out the magazine and check that the firearm is not loaded.**

Remove the charger pushing the charger button (no...).

Push the rear receiver pin out of the gun to the right. Do not use excessive force.

Push the front receiver pin and disassemble the upper part pushing it upwards.

## **Cleaning**

This product should be cleaned after every use and when exposed to dirt, sand, etc. When not in use, clean at least twice per year. A careful and scrupulous ordinary clearing of the firearms is essential to guarantee its safety and long life. We recommend to clean the weapon at least after shooting 200 to 300 rounds.

- ∞ Every time you use your gun it is advised to clean it in order to remove all corroding agents (humidity, powder or lead residues etc.) which can in time alter a few parts.
- ∞ In order to perform a standard clearing, it is sufficient to utilize a good solvent, cleaning oil, a little brush.
- ∞ For a deeper cleaning, please turn to your local gunsmith

**Warning: always run the cleaning rods from the chamber end**



Included with your American Tactical Firearm is a sample of Pro Gold MFR-7, a premium gun care and cleaning product. AmericanTactical Imports recommends the use of Pro Gold MFR-7 for all cleaning, lubricating, and protection needs for your firearm. This lubricant eliminates built up carbon and grease keeping your firearm clean. Please refer to the instruction booklet provided with your free sample of Pro Gold MFR-7 for the proper use of the product. The use of non recommended products may affect the performance and finish on your American Tactical firearm. Speak with your local dealer to have them stock Pro Gold MFR-7 lubricant products, if they do not already do so. Your dealer may locate a Pro-Gold Distributor by logging onto [firearms.progoldmfr.com](http://firearms.progoldmfr.com).

- Verify gun is ON SAFE.
- Remove charger and clean the retaining lips
- Visually inspect to verify that no ammo remains anywhere in the rifle.
- Remove receiver pins and disassemble the lower and upper parts.
- Thoroughly clean the bolt assembly area with a brush and cloth.
- Remove the sliding block and clean the ejector, breech block, bolt, battery (inside) and barrel breech.
- Clean the barrel with bore solvent utilizing a flexible cleaning rod inserted through breech end of barrel (where bullet seats). Dry the barrel with cleaning patches; always begin at the chamber. Repeat until barrel is clean.
  - Apply a thin coat of oil to all metal parts.
  - Reassemble firearm and check for proper function.

## **Ordinary and extraordinary maintenance**

- Before any sort of maintenance, make sure the firearm is unloaded.
- By "ordinary maintenance" we refer to measures the user should take to keep the gun in good working conditions.
- An "Extraordinary maintenance" implies the replacement of broken parts and therefore disassembling the gun. In this case only authorized personnel or a qualified gunsmith should operate.
- Also a long period of heavy use or inactivity requires an extraordinary maintenance; your gun should be taken to a qualified gunsmith to have the action disassembled for professional cleaning and lubrication.
- Your gunsmith will advise the best lubricant for the good maintenance of your revolver.
- Do not leave oil residues when cleaning and lubricating your firearm.
- Make sure that the mechanism of the weapon is easy; if it starts to stiffen, or if corrosion is starting on some essential parts, you should bring your gun to competent, professional personnel.
  - Do not use pure silicon or lanolin.
  - When ordering parts, it's important to specify date of purchase, serial number, model, caliber and item reference of the part/s needed.
  - If the gun has a problem that you cannot fix, DO NOT FIRE it but send it to an authorized center for a check-up. If you try to fix it personally, you may put in serious danger yourself and the people near you.
  - Always pay great attention and handle the gun very carefully, in order to avoid terrible accidents which may change your life and that of others.



## TROUBLESHOOTING TIPS

PROBLEM	CAUSE	SOLUTION
<b>Last Round Bolt Stop Failure</b>	Bolt travel not sufficient Too high velocity in recoil Dirt / Debris in Action	Use ammunition slightly faster, remember the gun is tuned to shoot ammo 325 m/sec Use ammunition slightly less powerful, too much velocity may compromise the correct functioning of the bolt stop If you have been shooting for a while or using ammunition with excessive fouling, it may be necessary to clean the firearm.
<b>The bolt doesn't cycle correctly or is stuck</b>	Not enough pressure to cycle Dirt / Debris in Action – in breech cycle Ammunition too short or too long for chamber.	Use Higher Velocity Ammo, remember the gun is tuned to shoot ammo 1050 fps (325 m/sec) or greater. Disassemble, clean carefully and oil the upper Check the ammunition / Consider different types of ammunition
<b>Fail to Fire (DNF)</b>	Bolt not completely closed Ammunition with rim out of tolerance Weak hammer spring Firing pin damaged or broken	Carefully clean the breech bolt and barrel & chamber area Change type or brand of ammunition Contact our service center Contact our service center to obtain a new firing pin
<b>Failure to Extract Empty Shell</b>	Dirty chamber Damaged Chamber Damaged Extractor Weak Extractor Spring	Clean cartridge chamber with cleaning brush Contact a professional gunsmith to polish the chamber Contact our service center to obtain a new extractor Contact our service center to obtain a new extractor spring
<b>The empty shell does not eject (stove pipe)</b>	Ammunition with rim out of tolerance Not enough pressure to cycle	Change type or brand of ammunition Use Higher Velocity Ammo, remember the gun is tuned to shoot ammo 1050 fps (325 m/sec) or greater.



<b>The bolt stays completely open</b>	Damaged ejector Dirty chamber Damaged chamber Damaged extractor Weak extractor spring Dirt / Debris in Action Weak recoil spring	Replace magazine  Clean cartridge chamber with cleaning brush  Contact a professional gunsmith to polish the chamber Contact our service center to obtain a new extractor  Contact our service center to obtain a new extractor spring  Disassemble and carefully clean the gun Contact our service center to obtain a new spring.
<b>Ammunition does not chamber</b>	Incorrect Ammunition	Check the ammunition and change type if necessary
<b>Magazine is stuck</b>	Dirt / Debris in action or chamber Magazine not properly seated Bullet crimp / design Dirt / Debris buildup Ammunition is too long	Disassemble and carefully clean the gun Check the magazine for correct fit and operation. Check the ammunition and change type if necessary  Clean the magazine thoroughly Change type of ammunition
<b>The gun fires with safety "On"</b>	Mechanical Issue	Do not attempt to use the gun, contact our service center immediately to arrange shipment of the gun
<b>The gun shoots low</b>	Rear sight needs adjustment	Lift the rear sight to raise the point of impact or vice versa to lower it.
<b>Shooting left or right (Windage)</b>	Rear sight needs adjustment	Move the rear sight the opposite direction of error (If POI "Point of Impact" is left of center, move the rear sight to the right)



## Service Instructions

Should your firearm, or any component of your firearm require service, kindly ship your entire firearm (please do not send components only), via your chosen carrier, postage paid (we do not accept C.O.D. shipments), following these instructions:

### **SERVICE**

---

You **MUST** email customer service **FIRST** at [techservice@americantactical.us](mailto:techservice@americantactical.us) and provide a detailed description of the problem. Be sure to provide make, model, and serial number of the firearm, as well as the owner's name, address (no P.O. boxes please), and phone number. A customer service agent will contact you normally within one business day. You will then receive a service repair tag that must be attached to each firearm by matching the serial number on the tag to your firearm. There will be a claim check number on the tag that must be detached from the tag and taped firmly to the outside of the return package near the shipping label. Returns will be refused without this tag visibly showing on the outside of the package. Also, be sure to carefully follow all instructions listed below:

- **Make absolutely certain your firearm is unloaded.**
- Do not send ammunition with your firearm.
- Remove all accessories from your firearm such as scopes, slings, mounts, etc.
- Ship your firearm in a suitable container, packaging it securely to prevent parts from shifting and/or harm during shipping.
- It is advisable to place your correspondence inside your shipping container when shipping.
- Tape the control number stub on the outside of the package as described above.

### **SHIPPING ADDRESS**

American Tactical Imports  
100 Airpark Drive  
Rochester, New York 14624  
Attn: Service

If you have any questions, please contact the Product Service Center by email at [techservice@americantactical.us](mailto:techservice@americantactical.us).





## Service Instructions

### **TO ORDER PARTS FROM THE FACTORY SERVICE CENTER**

To order parts, you can fax, phone, mail, or e-mail your order to us at one of the below numbers/addresses.

Fax Number: (830) 773-5893  
Phone Number: (800) 290-0065  
E-mail Address: [customerservice@americantactical.us](mailto:customerservice@americantactical.us)  
Mailing Address: American Tactical  
Attn: Service  
100 Airpark Drive  
Rochester, New York 14624

Please provide your name, address, city, state, zip, your daytime phone number and e-mail address. We will need the Model #, Serial #, Gauge/Caliber, Finish, Part # and Part Name.

We accept most major credit cards, money orders, and bank drafts.

### **Service Outside of the U.S.A.**

For American Tactical International firearm parts and service requirements outside of the United States, customers are requested to contact the closest American Tactical International stocking dealer/distributor.



## Warranty Statement

### **Warranty Policy & Procedure**

American Tactical Imports provides limited 2 year warranty services, parts, and repairs for our firearms. If you believe your ATI product or ATI brand product needs service or replacement, please email [techservice@americantactical.us](mailto:techservice@americantactical.us). In said email, be sure to provide: make, model, serial number, and caliber of the firearm in question; as well as the owner's name, address, city, state, zip, email address and phone number. One of our representatives will assist you and provide further instructions.

All returns for service or repair require a Return Authorization (RA) number to be issued by an ATI representative. No returns for service will be accepted without an ATI issued RA number written clearly on the outside of the package. Any items received without an ATI issued RA number will be returned to the sender without action. *SEE "SERVICE" ON PAGE 12.*

Service time frame may vary due to service queue and availability of parts from foreign manufacturers. It is the responsibility of the consumer to ship any firearms or products to ATI for service. All firearms must be registered online at [www.americantactical.us](http://www.americantactical.us) before an ATI representative can issue a return authorization number. If an item received is outside of warranty coverage, an ATI representative will contact you before further action is taken.

The warranties covered by ATI are implemented and monitored by the various manufacturers of all ATI products. ATI reserves the right to deny or decline any warranty services or products that do not meet the warranties implemented by our manufacturers.

If you are returning a rifle or shotgun for service, you may ship to ATI via US Postal Service or any parcel delivery service directly to ATI.

If you are returning a pistol, it is the responsibility of the owner to contact a local FFL to ship to ATI. All warranty service information must be provided by the FFL who is shipping the pistol.

All firearms returned to ATI for service can only be shipped back to the original senders address. Change of return shipping address once received is not authorized. Pistols can only be shipped to and from FFL locations.



## Warranty Statement

### **What is not covered under warranty?**

We will not cover damage of your OMNI caused by:

- Failure to provide proper care and maintenance
- Accidents, abuse or misuse
- Barrel obstruction
- Hand loaded, reloaded or improper ammunition
- Unauthorized adjustments, repairs or modifications
- Normal wear and tear

### What is excluded from this warranty?

American Tactical Imports excludes and will not pay incidental or consequential damages under this warranty. By this we mean any loss, expense or damages other than to repair defects in the OMNI or replace the OMNI. No implied warranties extend beyond the term of this written warranty.

### **PLEASE REGISTER YOUR FIREARM'S WARRANTY ONLINE AT:**

[www.AmericanTactical.us](http://www.AmericanTactical.us)



## MAINTENANCE NOTES



TM

AMERICAN TACTICAL